

Electromagnetic dancer EDL 60

With processor controlled Easy-Driver EDD V5

The electromagnetic dancer is a high-precision tension regulator, e.g. for unwinding, winding and rewinding processes for wires and fibers.

Due to the patented electromagnetic force method of the electromagnetic dancer, the traction force always remains constant.

All the necessary functions for tension control are already included in the associated electronics, the EDD:

- Tension regulator
- Dancer position controller
- RPM control for a drive engine
- Dancer position output with break detection

The parameterization of the dancer position controller and the tension adjustment of the electromagnetic dancer can be done serially via USB or RS485. Alternatively, analog inputs are also available for the tension setting.

A comfortable setting is possible with the software SUMMI easy or SUMMI pro or with the operating unit CMC.

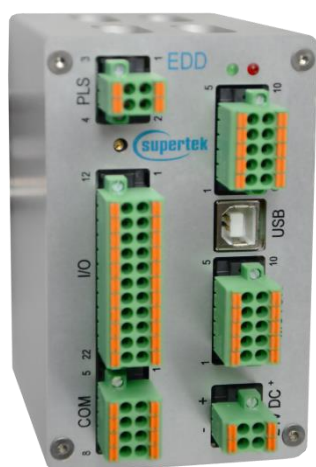

Electromagnetic dancer EDL 60

Tension range Single wound	10cN to 600cN
Dancer force	20cN to 1200cN
Generation of force	electromagnetic
Dancer force position independent	Yes
Position measurement, integrated	Yes, contactless
Dancer stroke linear	Yes
Dancer stroke	47mm
Weight	3kg
Operating temperature	10 – 40°C
Mountage	See page 2
Electronics	EDD
Pulleys	optional

Processor controlled Easy-Driver EDD V5

Rated voltage	24V DC
Current, max.	1A
Mountage	Hat rail 35mm
Dimensions: w, h, d	64, 105, 113mm
Dancer position output	0-10V
Dancer position controller	Yes, PI-Controller
Correcting variable as rotational speed of motor	0-10V pulse/direction
Potential-free outputs	4
Output-signal dancer position up	Yes
Output-signal dancer position down	Yes
Adjustment of dancer force	automatic
Tension setting analog	Yes, 2X 0-10V
Tension setting seriell	Yes, RS485, USB
Tension setting	in 1mN steps
Parameterization, setting, operation	
Software SUMMI easy	Yes
Software SUMMI pro	Yes
Operator and control unit CMC	Yes

Description	Item no.:
Set consisting of dancer EDL 60 and Easy-Driver EDD V5	EDL60EDDV501
Connecting line EDL with EDD	
3m	LTGEDD3M
5m	LTGEDD5M
10m	LTGEDD10M
Pulleys	On request
Software SUMMI easy	SUMMIEASY
Software SUMMI pro	SUMMIPRO
Compact operator and control unit CMC	CMC01

Mountage, Electromagnetic dancer EDL 60

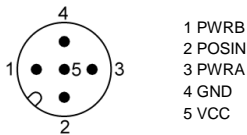
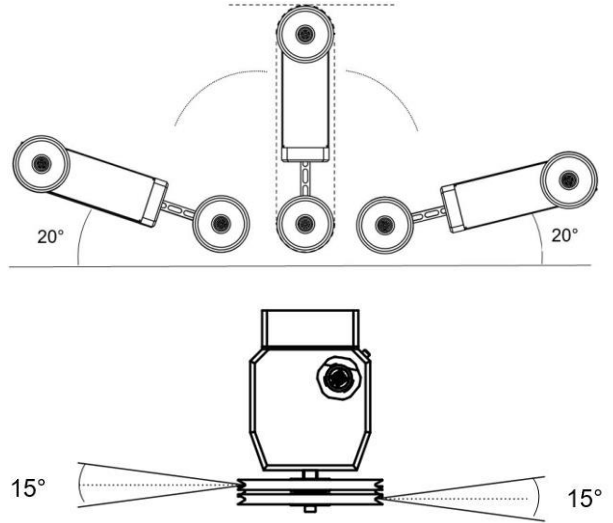
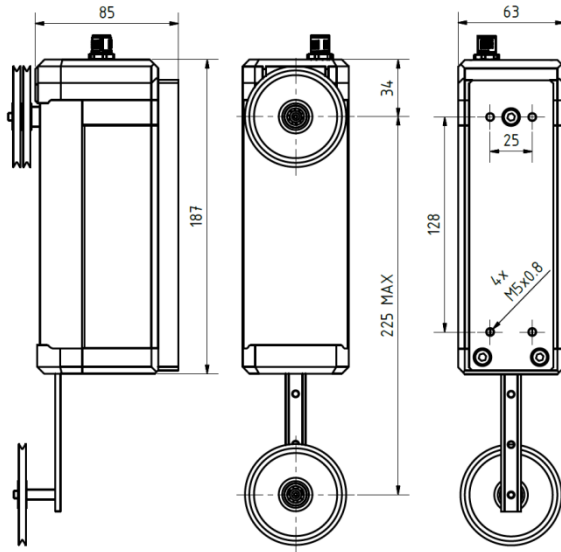

Connection diagram, Processor controlled Easy-Driver EDD V5

